

WINCH

WINCH FOR LIFTING PERSONNEL OR MATERIALS

FEATURES

- Up to 250 kg MWL
- Heavy duty
- Anti-run brake
- Up to 40 m rope
- Galvanised or stainless steel rope

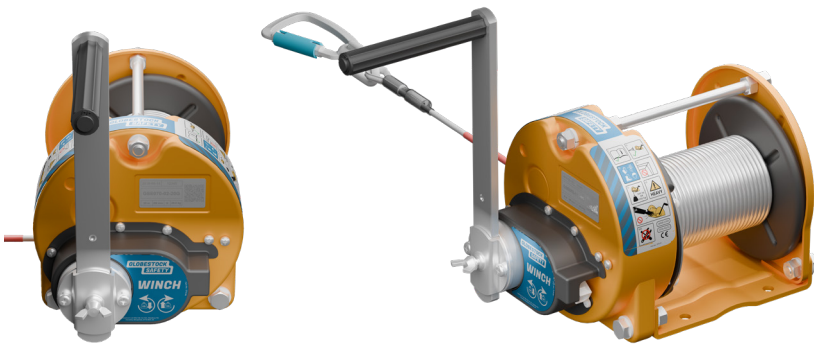
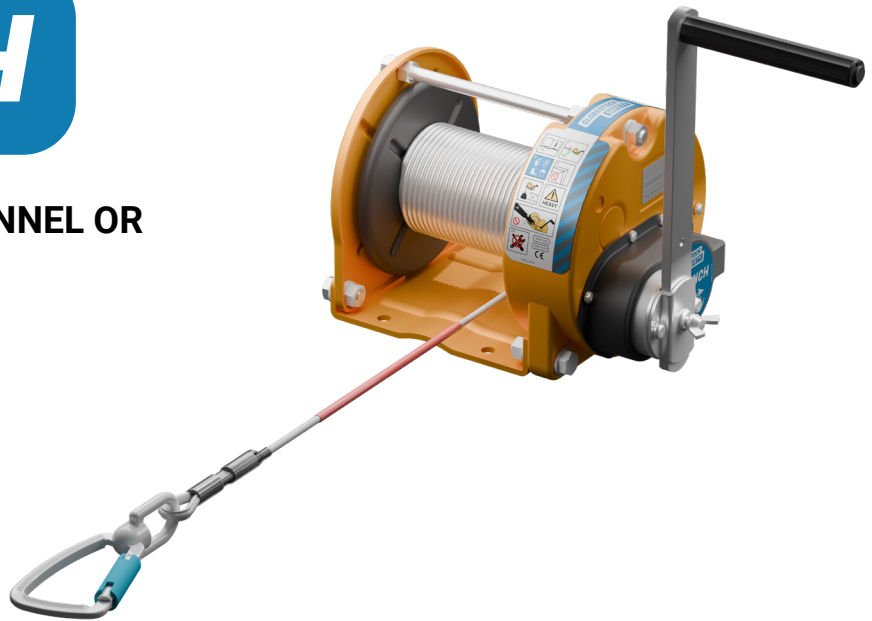

WINCH fitted to a SENTRY Tripod



INFORMATION

The Globestock WINCH is specifically certified for the lifting of both personnel and materials. It is a personnel winch that may also be used for load lifting.

The anti-run braking mechanism means that, if the winding arm is released during lifting, the winch automatically locks, holding the person / load steady until the handle is rotated again by the operator.

The 1:8.9 gear ratio makes personnel lifting easy, and delivers 50 mm of rope retrieval per rotation.

May be mounted to various anchorages, including the SENTRY Tripod and XTIR-PA range.

Product Code	MWL	Weight (Approx.)	Max. Rope Length	Rope Kit	Conformity
GSE070-20G	250 kg	20.5 kg	20 m	Galvanised steel rope & alu karabiner	CE
GSE070-40G		22 kg	40 m		
GSE070-40SSK	200kg	22 kg	40 m	Stainless steel rope & alu karabiner	

DIMENSIONS

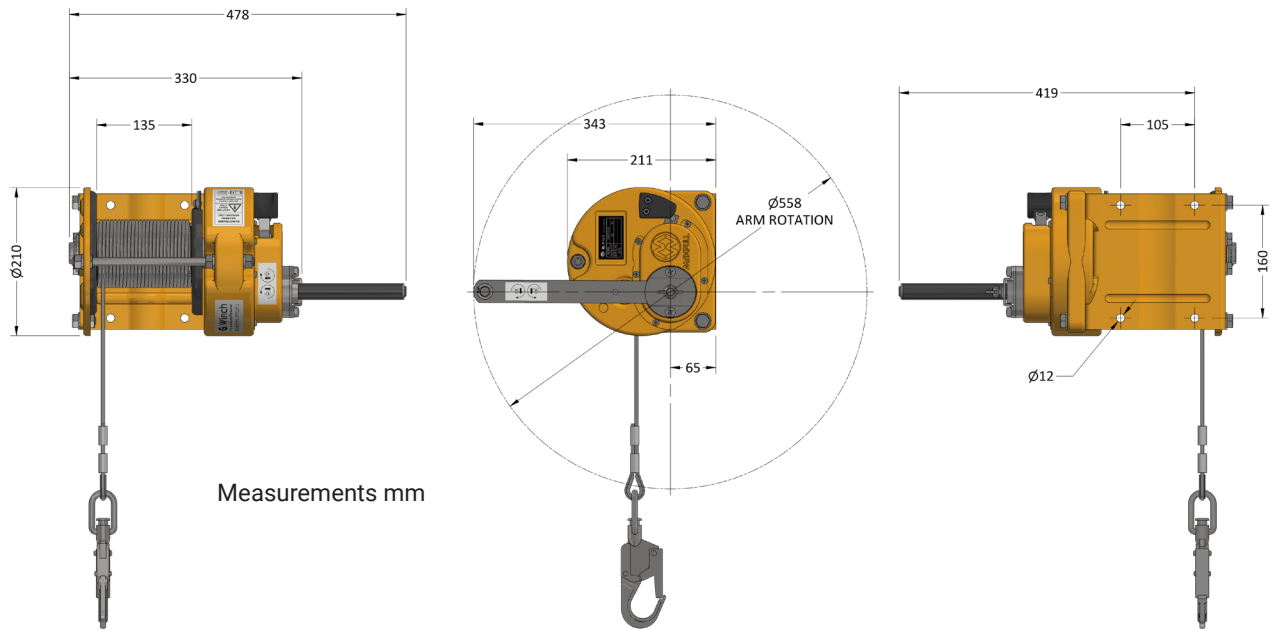

ACCESSORIES



WINCH Bracket
(for XTIRPA anchorages)
GSE200WBX

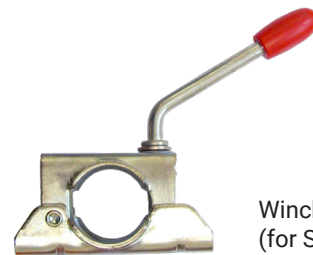

Winch Bracket Assembly x2
(for SENTRY Tripod)
GSE200WBK



Holdall bag
GSE-H/ALL



250 kg Lifting Pulley
GSE070250USP